

1 dimensions in mm

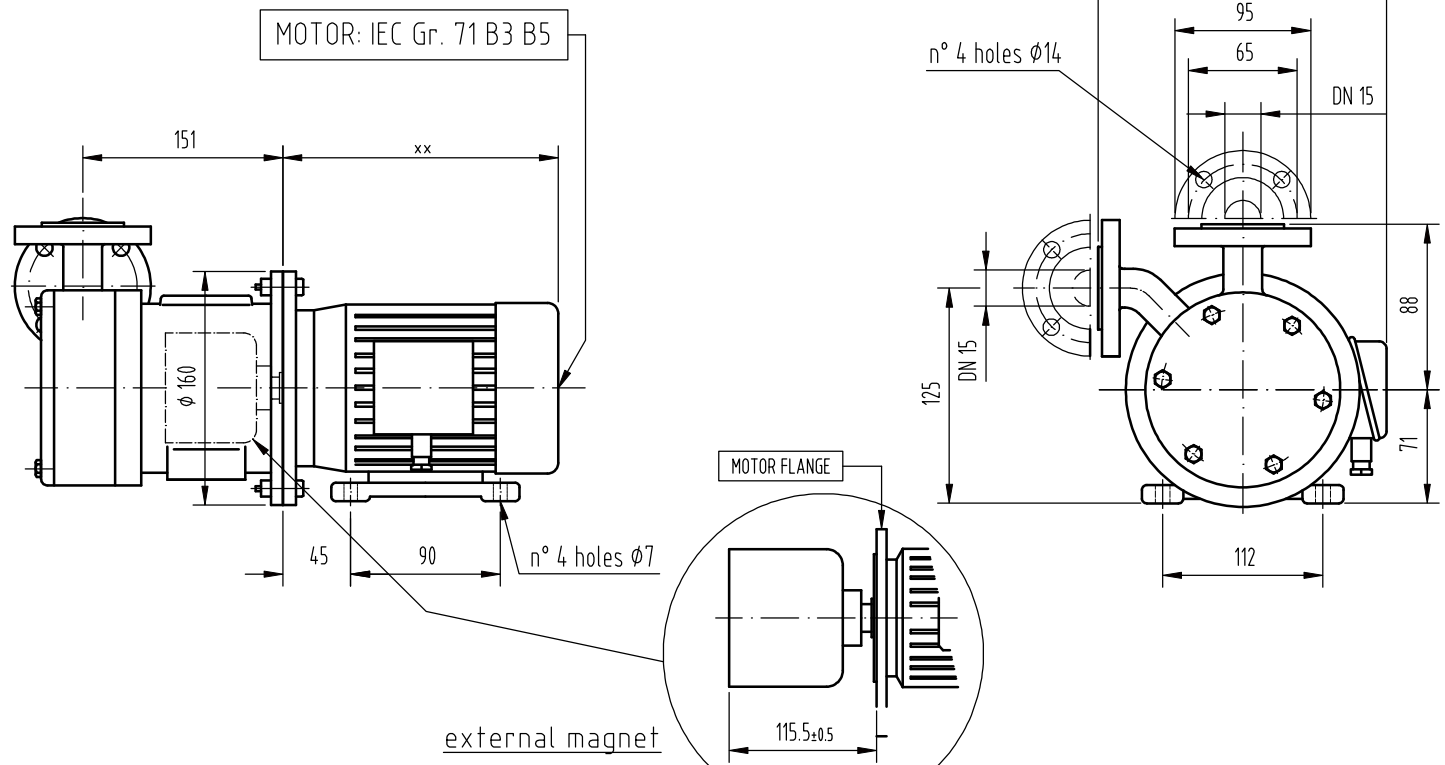

⊗ DIFFERENT FROM MOTOR MANUFACTURER  
- DIRECTION AND PORTS LOCATION ARE REVERSIBLE

FLANGED DIN 2633 PN 16

REF	DESCRIPTION	MATERIAL	CODE
10	Containment shell	SS 316L	
20	Ext. Magnet	CoSm/ Carbon Steel	
30	Int. Magnet	SS 316L/CoSm	
40	Impeller	SS 316L	
50	Set O-Rings (a+b+c) a + b = O-Ring 4250 (230) c = O-Ring 4312 (235)	Viton	
61	Thrust Bearings	Pcarbon	
62	Rear Ring	SS316L	
70	Shaft	SS316L	
75	Sleeve Bearings Bearings (d+e) Bearing (f)	Pcarbon SS316	
78	Bracket (160-110-14)	CAST IRON	
79	Rub Ring	Bronze	
84	End Cover	SS 316L	
85	Pump Casing	SS 316L	
88	Rear Wet End (10+30+40+50+61+62+70+75)	/	

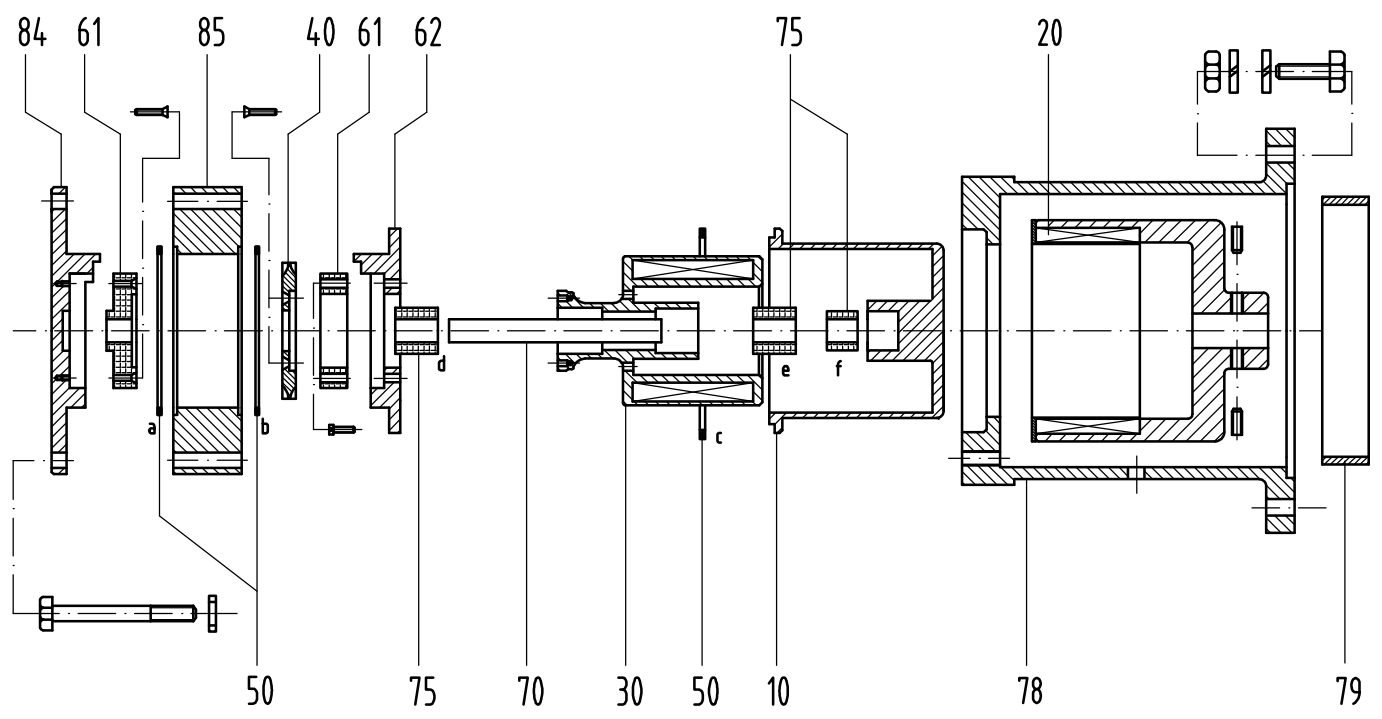

**MARCH PUMPEN GmbH & Co.KG**  
 Rathenastraße 2  
 D-35394 Gießen  
 www.march-pumpen.com  
 info@march-pumpen.com

Baureihe / Series:	MTA
Typ / Type:	MTA 25 SSF
Motor:	IEC 71 B35